



CT35 PRO

ELICA DESIGN CENTER

60 - 90 - 120 cm
 Extraction Afzuiging
 Acier inoxydable Roestvrij staal

- TOTAL INTEGRATION
- DELAY SWITCH OFF
- ENTRETIEN FACILE
- ALARME MAINTENANCE
- ASPIRATION ARRIERE
- CM 50
- CM 65
- Ø150
- CLASSE ÉNERGÉTIQUE (A++/D)

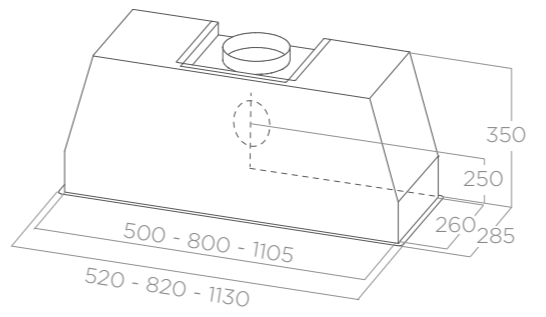

ECLAIRAGE VERLICHTING

Type Type	STRIP LED 2x3W		
60cm	90cm	120cm	
Intensité Intensiteit	121 LUX	97 LUX	73 LUX
Température Temperatur	4200 K	4200 K	4200 K

PERFORMANCE PRESTATIE

Commandes Bedieningen	Touch control 3V+I Elektronisch bedieningspaneel 3S+I		
60cm	90cm	120cm	
Aspiration intensive Boostervermogen	650 m³/h	750 m³/h	780 m³/h
Niveau sonore min-max Geluidsniveau min-max	51 - 73 db(A)	50 - 69 db(A)	52 - 69 db(A)
Absorption totale Totale absorptie	281 W	281 W	281 W

Filtre type professionnel en acier inoxydable inclus
 Professional RVS filter meegeleverd

ACCESSOIRES TOEBEHOREN

Moteur à distance pour l'extérieur (GME11) Externe motor voor gebruik buitenshuis (GME11)	PRF0006209A
Moteur à distance pour l'extérieur (GME22 A) Externe motor voor gebruik buitenshuis (GME22 A)	PRF0179706

MODÈLES MODELLEN

CT35 PRO IX/A/60	PRF0183203
CT35 PRO IX/A/90	PRF0183209
CT35 PRO IX/A/120	PRF0183210
CT35 PRO GME IX/A/60	PRF0183213
CT35 PRO GME IX/A/90	PRF0183218
CT35 PRO GME IX/A/120	PRF0183219